



# HALF BALL LENSES FOR HIGH POWER LED.

Notice: Specification, description and dimensional data are for information only, they are subject to correction or change without notice or incurring obligation.

## Introduction

Half ball lenses are specially designed for the use in the field of LED lighting. They are intended for the production of very large quantities. Prices comparable with the price of plastic lenses are combined with all the very useful characteristics of three different glass types:

- ▲ High surface quality
- ▲ Scratch-proof surface
- ▲ High or very high refraction index
- ▲ Heat resistant up till more than 300°C (572°F)

How to find the right glass type:

In most cases, B270 will be the best choice. It is a very high quality optical glass at a very good price. Its thermal expansion rate lies within a good range, but not as good as that of Borosilicate glass.

If you need a very high refraction index, F2 will be a good choice. It is a special optical glass at a much higher price as B270 or Borosilicate glass, and is thus not a standard glass in stock.

If you require a very low thermal expansion rate combined with a mid-range refraction index, Borosilicate glass will be the first choice. The price of this glass lies between that of B270 and F2. Half ball lenses of Borosilicate glass are not available from stock.

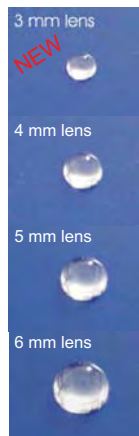

## Weight of half ball lenses with different diameters and different glass types in gramm per 1,000 pcs

Made from B270					Gramm per 1,000 pcs.
	3mm	4mm	5mm	6mm	
Standard	18.3	42.7	83.4	144.2	
Truncated	12.7	33.2	68.5	122.6	
Extended	23.4	52.3	98.4	165.8	

Made from Borosilicate Glass					Gramm per 1,000 pcs.
	3mm	4mm	5mm	6mm	
Standard	15.8	37.4	73.0	126.1	
Truncated	11.1	29.0	59.9	107.2	
Extended	20.5	45.7	86.0	145.0	

Made from F2					Gramm per 1,000 pcs.
	3mm	4mm	5mm	6mm	
Standard	25.2	60.5	118.1	204.1	
Truncated	18.0	47.0	97.0	173.6	
Extended	33.2	74.0	139.3	234.7	

- Standard types are available at short notice. Prototypes are typically available from stock.
- Truncated as well as extended versions are available on request. Please allow some weeks of production time for prototypes if there are none on stock.
- There are no tooling costs for all types shown here.

Notice: Specification, description and dimensional data are for information only, they are subject to correction or change without notice or incurring obligation.

### Standard thickness

Diameter	6.00 ± 0.10 mm
Thickness	3.00 ± 0.15 mm
Radius	(3.00 mm)
Focal Length	(5.74 mm)
Material	Glass
	B 270 (Schott)
Refraction Index	$n_d = 1.5230$ (@588nm)
Thermal Expansion Index	$95 \times 10^{-7} / K$

standard hemisphere lens D60R30H30

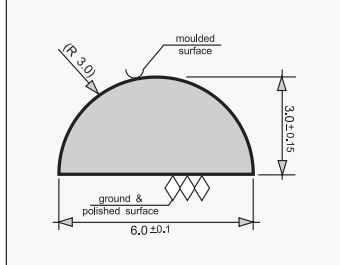

### Truncated

Diameter	6.00 ± 0.10 mm
Thickness	2.70 ± 0.15 mm
Radius	(3.00 mm)
Focal Length	(5.74 mm)
Material	Glass
	B 270 (Schott)
Refraction Index	$n_d = 1.5230$ (@588nm)
Thermal Expansion Index	$95 \times 10^{-7} / K$

truncated hemisphere lens D60R30H27

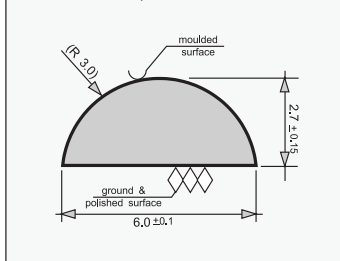

### Extended

Diameter	6.00 ± 0.10 mm
Thickness	3.30 ± 0.15 mm
Radius	(3.00 mm)
Focal Length	(5.74 mm)
Material	Glass
	B 270 (Schott)
Refraction Index	$n_d = 1.5230$ (@588nm)
Thermal Expansion Index	$95 \times 10^{-7} / K$

extended hemisphere lens D60R30H33

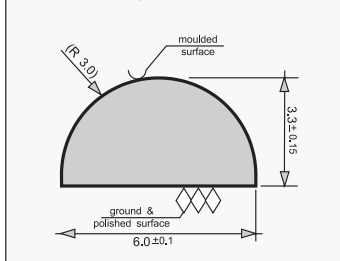

# Half Ball Lenses

Notice: Specification, description and dimensional data are for information only, they are subject to correction or change without notice or incurring obligation.

- Standard types are available at short notice. Prototypes are typically available from stock.
- Truncated as well as extended versions are available on request. Please allow some weeks of production time for prototypes if there are none on stock.
- There are no tooling costs for all types shown here.

## Standard thickness

Diameter	5.00 ± 0.10 mm
Thickness	2.50 ± 0.15 mm
Radius	(2.50 mm)
Focal Length	(4.78 mm)
Material	Glass
	B 270 (Schott)
Refraction Index	$n_d = 1.5230$ (@588nm)
Thermal Expansion Index	$95 \times 10^{-7} / K$

standard hemisphere lens D50R25H25

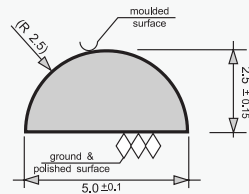

## Truncated

Diameter	5.00 ± 0.10 mm
Thickness	2.20 ± 0.15 mm
Radius	(2.50 mm)
Focal Length	(4.78 mm)
Material	Glass
	B 270 (Schott)
Refraction Index	$n_d = 1.5230$ (@588nm)
Thermal Expansion Index	$95 \times 10^{-7} / K$

truncated hemisphere lens D50R25H22

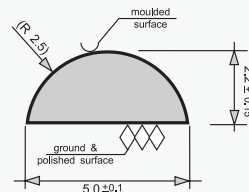

## Extended

Diameter	5.00 ± 0.10 mm
Thickness	2.80 ± 0.15 mm
Radius	(2.50 mm)
Focal Length	(4.78 mm)
Material	Glass
	B 270 (Schott)
Refraction Index	$n_d = 1.5230$ (@588nm)

extended hemisphere lens D50R25H28

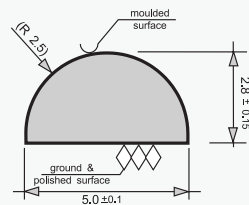

5.00 mm Diameter / Radius 2.50 mm

- Standard types are available at short notice. Prototypes are typically available from stock.
- Truncated as well as extended versions are available on request. Please allow some weeks of production time for prototypes if there are none on stock.
- There are no tooling costs for all types shown here.

### Standard thickness

Diameter	4.00 ± 0.10 mm
Thickness	2.00 ± 0.15 mm
Radius	(2.00 mm)
Focal Length	(3.82 mm)
Material	Glass
	B 270 (Schott)
Refraction Index	$n_d = 1.5230$ (@588nm)
Thermal Expansion Index	$95 \times 10^{-7} / K$

standard hemisphere lens D40R20H20

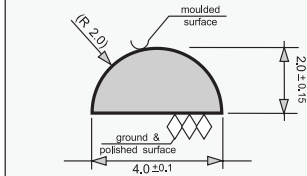

### Truncated

Diameter	4.00 ± 0.10 mm
Thickness	1.70 ± 0.15 mm
Radius	(2.00 mm)
Focal Length	(3.82 mm)
Material	Glass
	B 270 (Schott)
Refraction Index	$n_d = 1.5230$ (@588nm)
Thermal Expansion Index	$95 \times 10^{-7} / K$

truncated hemisphere lens D40R20H17

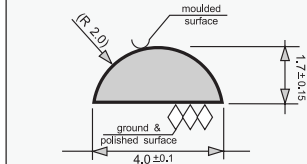

### Extended

Diameter	4.00 ± 0.10 mm
Thickness	2.30 ± 0.15 mm
Radius	(2.00 mm)
Focal Length	(3.82 mm)
Material	Glass
	B 270 (Schott)
Refraction Index	$n_d = 1.5230$ (@588nm)
Thermal Expansion Index	$95 \times 10^{-7} / K$

extended hemisphere lens D40R20H23

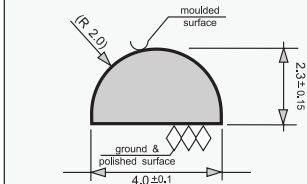

Notice: Specification, description and dimensional data are for information only, they are subject to correction or change without notice or incurring obligation.

# Half Ball Lenses

3.00 mm Diameter / Radius 1.50 mm

Notice: Specification, description and dimensional data are for information only, they are subject to correction or change without notice or incurring obligation.

- Standard types are available at short notice. Prototypes are typically available from stock.
- Truncated as well as extended versions are available on request. Please allow some weeks of production time for prototypes if there are none on stock.
- There are no tooling costs for all types shown here.

## Standard thickness

Diameter	3.00 ± 0.10 mm
Thickness	1.50 ± 0.15 mm
Radius	(1.50 mm)
Focal Length	(2.86 mm)
Material	Glass
	B 270 (Schott)
Refraction Index	$n_d = 1.5230$ (@588nm)
Thermal Expansion Index	$95 \times 10^{-7} / K$

standard hemisphere lens D30R15H15

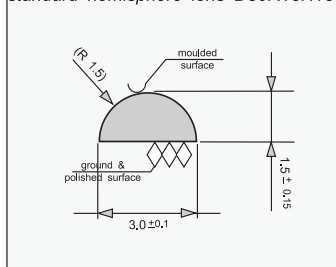

## Truncated

Diameter	3.00 ± 0.10 mm
Thickness	1.20 ± 0.15 mm
Radius	(1.50 mm)
Focal Length	(2.86 mm)
Material	Glass
	B 270 (Schott)
Refraction Index	$n_d = 1.5230$ (@588nm)
Thermal Expansion Index	$95 \times 10^{-7} / K$

truncated hemisphere lens D30R15H12

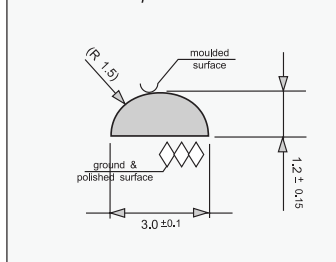

## Extended

Diameter	3.00 ± 0.10 mm
Thickness	1.80 ± 0.15 mm
Radius	(1.50 mm)
Focal Length	(2.86 mm)
Material	Glass
	B 270 (Schott)
Refraction Index	$n_d = 1.5230$ (@588nm)
Thermal Expansion Index	$95 \times 10^{-7} / K$

extended hemisphere lens D30R15H18

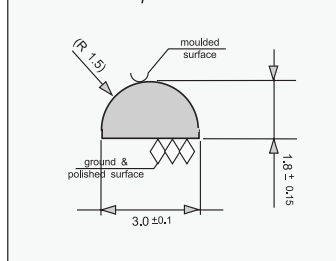

### Standard glass

B270 Superwite® by Schott is a high-quality optical glass with an excellent transmission in long wavelengths.

Docter Optics GmbH has specialised in manufacturing aspherical lenses, mirrors, prisms, and other optical components from this glass, using a blank moulding process.

High-quality Half Ball Lenses, in extremely large quantities and at the lowest cost, are the latest development of Docter Optics GmbH. Blank moulded lenses offer the best cost-effectiveness.

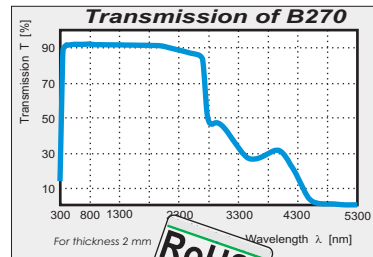

thermal expansion index (+20 .. +300 °C)	$95 \times 10^{-7} / K$
Refraction index	$n_d = 1.5230$

### Borosilicate glass

Comparable, known glass types are Duran® by Schott or Pyrex® by Corning.

Borosilicate glass is used where a low thermal expansion index is required.

Thermal expansion index of Borosilicate glass is close to the index of ceramics. The refraction index of Borosilicate glass is close to the index of plastic. They fulfill RoHS and WEEE.

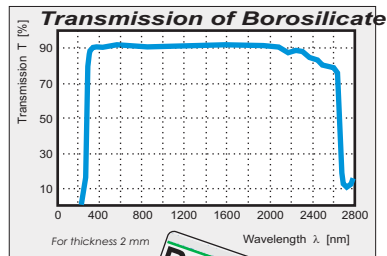

thermal expansion index (+20 .. +300 °C)	$32 \times 10^{-7} / K$
Refraction index	$n_d$ approx. 1.48

### F2 glass

High-quality optical glass, by Schott, with a high refraction index.

The expansion index is a little bit better than the index of B270, but the price of F2 is much higher.

So, F2 is the best glass where a much higher refraction index than B270 is a must. **F2 fulfills RoHS and WEEE for the next 4 years (2005/74/EC)**

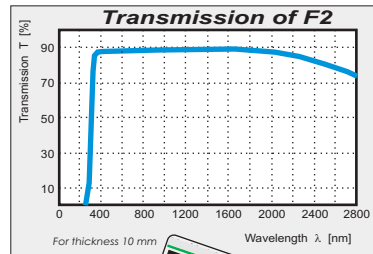

thermal expansion index (-30 .. +70 °C)	$82 \times 10^{-7} / K$
Refraction index	$n_d = 1.62004$

### Packaging

Our goods come in plastic bags of 1,000 or 10,000 pcs. as a standard. Packaging can be subject to discussion on the basis of the customer's requirements. In the case of customer specific packaging the additional costs will be added on the invoice.

### Shipping

All prices are ex works (EXW). Shipping can be arranged by *Docter Optics GmbH*. In that case the shipping costs will be added on the invoice.

### Quantities & payment terms

Half ball lenses are ordered by quantity. The lowest quantity should be 10,000 pcs. per diameter and thickness and glass type. Typical payment terms are open invoice, to be paid within 30 days net. Normally, *Docter Optics GmbH* will issue the invoices in Euro.

### More information

For more information you can contact *Docter Optics GmbH* any time. To get a quotation for a standard, truncated or extended version or for more information concerning other shapes, lens arrays, or aspheric LED lenses send an **eMail to** [INFO@DOCTEROPTICS.COM](mailto:INFO@DOCTEROPTICS.COM)  
**or call** +49 36481 27-0 **or fax** +49 36481 27-270

### Other shapes

Blank moulding allows *Docter Optics GmbH* to produce nearly any kind of geometry and combinations of lenses that can be created by optics developers and system designers. The geometry of the optically effective surface is not restricted to radii; blank moulding allows to produce lenses with aspherical surfaces. There are many applications in which aspheric lenses will improve the performance of technical and optical systems.

Many applications need lenses in fly-eye-array.



Blank moulding allows to produce just the right array you need. This helps to save assembly costs.

Please note  the



For your information:

DOCTER OPTICS lenses made from  
**B270 glass**  
and DOCTER OPTICS lenses made from  
**Borosilicate glass**  
and DOCTER OPTICS lenses made from  
**F2 glass**  
**fulfill** all requirements concerning:

**German “Elektro- und Elektronikgesetz (ElektroG)” §5(1)**

**“Restriction on the use of certain hazardous substances in  
electrical and electronic equipment (RoHS)”  
2002/95/EC**

**“Waste Electrical and Electronical Equipment Directive  
(WEEE)”  
2002/96/EC**

**Guideline to the RoHS by the European Commission,  
published in May 2005, §2.2**

**NEW**

**Commission Decision of 21 Oct 2005  
2005/747/EC**

## Request for more Information / Quotation

Notice: Specification, description and dimensional data are for information only, they are subject to correction or change without notice or incurring obligation.

Company
Contact
Phone
Fax
eMail

**Aspheric shape** pls. provide formula

**-- or --**

**Radius=** ..... **mm**

Thickness

mm  $\pm$  0.15

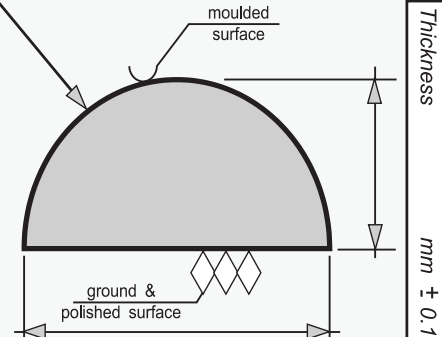

Diameter

mm  $\pm$  0.1

**glasstypes**

pls. tick one box only

**B270** (Standard glass)

**F 2**

**Borosilicate glass**

**expected Quantity** ..... **k pcs.**

pls. Tick one box only

**single order**

**per month**

**per year**

**Fax to: +49 36481 27-0**

**or eMail to: info@DocterOptics.com**

## **Headquarters**

### **DOCTER® OPTICS GmbH**

Mittelweg 29  
07806 Neustadt an der Orla  
Germany

Phone: +49 36481 27-0  
Fax: +49 36481 27-270

[info@docteroptics.com](mailto:info@docteroptics.com)

## **Express Glass Services**

### **DOCTER® OPTICS GmbH**

Straße der Deutschen Einheit 6  
07819 Triptis  
Germany

Phone: +49 36482 88173  
Fax: +49 36482 88174

[egs@docteroptics.com](mailto:egs@docteroptics.com)

## **North America**

### **DOCTER® OPTICS, INC.**

1425 West Elliot Road  
Suite A-105  
Gilbert, AZ 85233 USA

Phone: +1 480 844 7585  
Fax: +1 480 844 7826

[doi@docteroptics.com](mailto:doi@docteroptics.com)

## **Japan**

### **DOCTER® OPTICS JAPAN**

General Bldg., 2F  
No. 25-20, Sakashita 1-Chome  
Itabashi-ku, Tokyo 174-0043 Japan

Phone: +81 3 3969 3731  
Fax: +81 3 3969 3732

[docter.optics@genexco.org](mailto:docter.optics@genexco.org)

[www.docteroptics.com](http://www.docteroptics.com)

---